

© DEN HARTOG INDUSTRIES, INC.

Copyright. All information furnished within this document, electronic file or design correspondence is the property of Den Hartog Industries, Inc. and shall not be used, disclosed to others or copied without the expressed written consent of Den Hartog Industries, Inc.

STANDARD TANK ASSEMBLY

TANK ASSEMBLY WITH OPTIONAL FITTING

DW0150-36

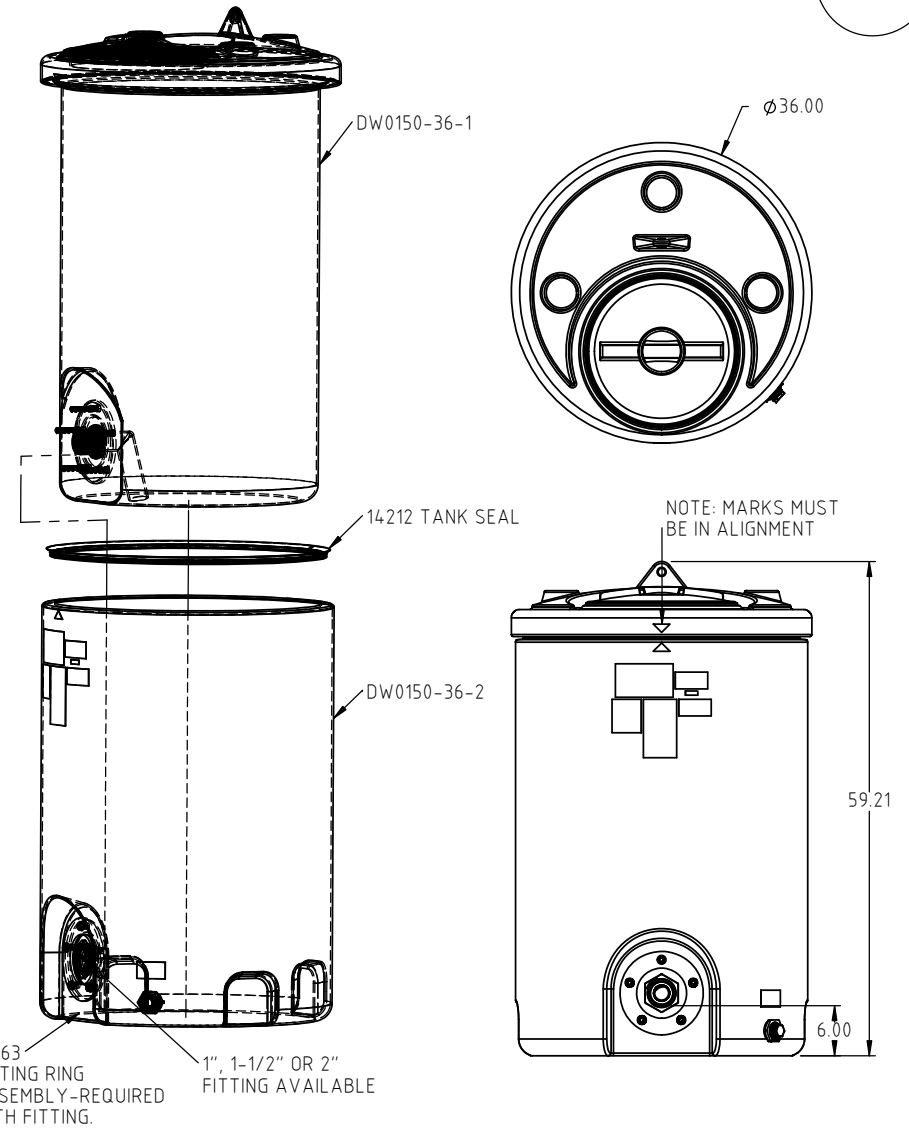
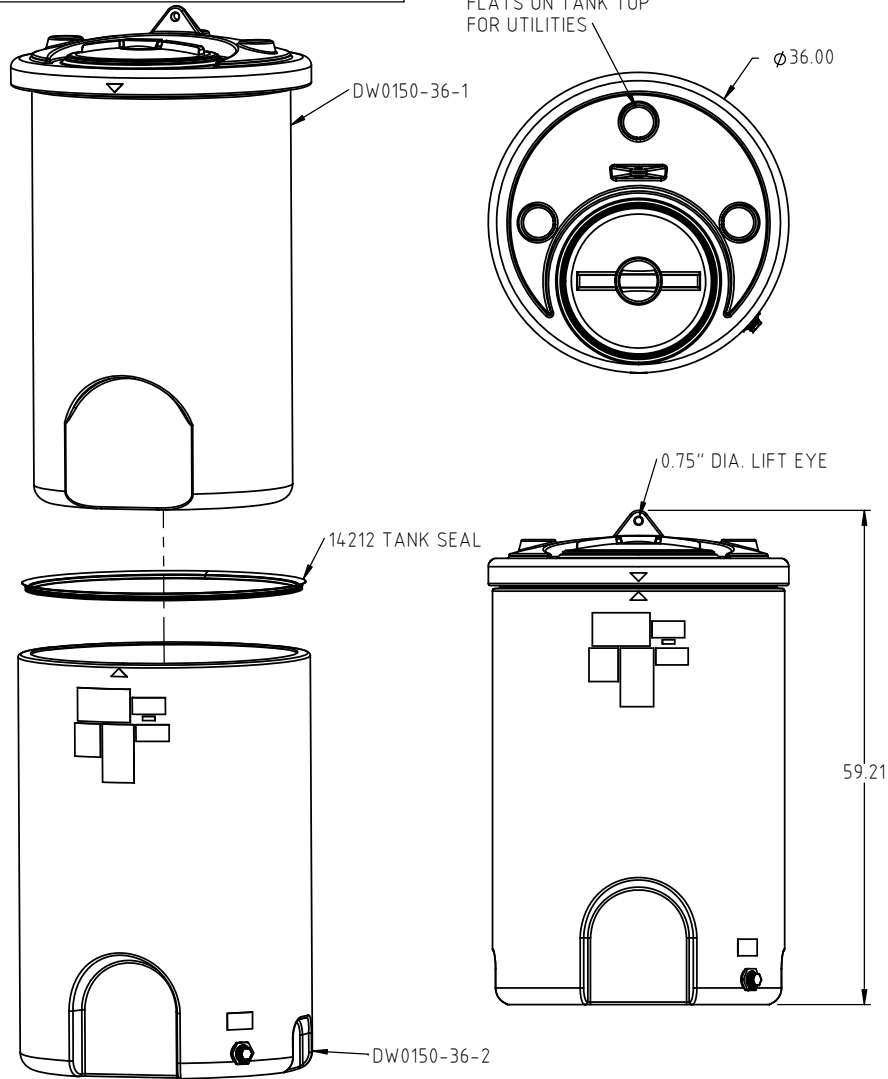

REV	DESCRIPTION	BY / DATE	CCN	DRAWN / DATE ADH 8/28/14	MATERIAL SEE NOTE 1.
				APPRD. / DATE REH 10/17/14	
	ALL DIMENSIONS ARE IN DECIMAL INCHES TOLERANCES UNLESS OTHERWISE SPECIFIED	THIRD ANGLE PROJECTION ANSI 14.5M		SHOT WEIGHT:	NOTES: 1.) REFERENCE COMPONENT PRINTS FOR DETAILS 2.) PATENT PENDING
	POLYETHYLENE ±1% @ 68°F			SHIPPING WEIGHT: STANDARD = 99 LBS. FINISH:	



Den Hartog
INDUSTRIES, INC.

Ace Roto-Mold Injection Molding Blow Molding Sowjoy

4010 HOSPERS DRIVE S. BOX 425, HOSPERS, IOWA 51238-0425

DESCRIPTION 150 GALLON DUAL LINE™ TANK ASSEMBLY	
SCALE N.S.	PART NO. DW0150-36

Copyright. All information furnished within this document, electronic file or design correspondence is the property of Den Hartog Industries, Inc. and shall not be used, disclosed to others or copied without the expressed written consent of Den Hartog Industries, Inc.

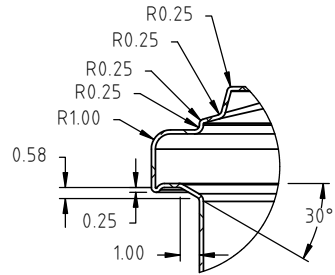

DETAIL A
SCALE 1:10

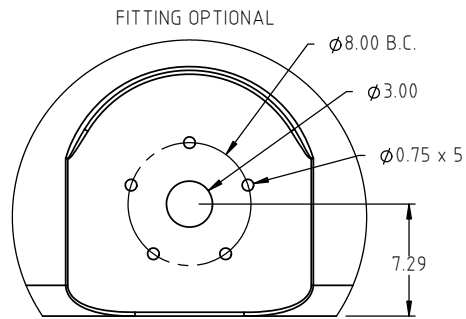
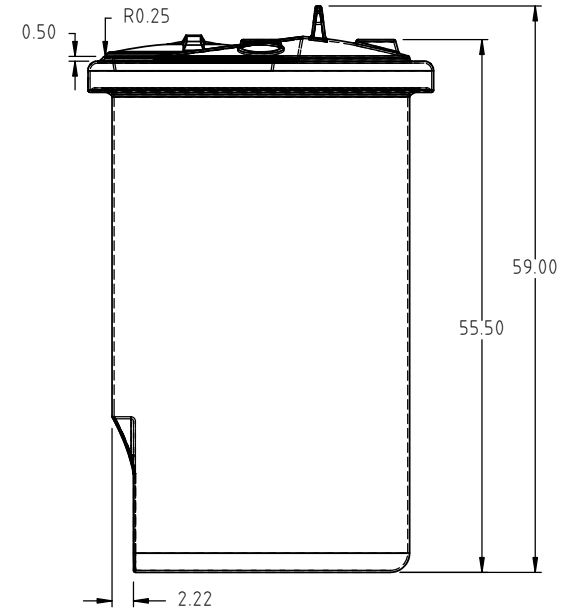
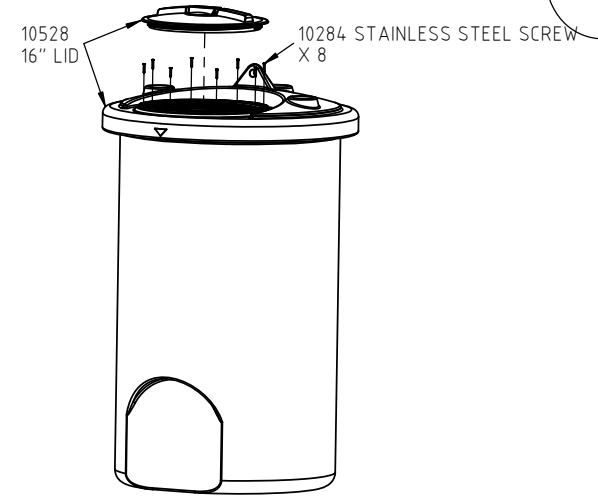
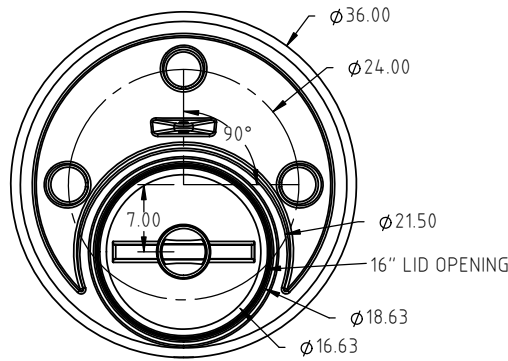

DETAIL B
SCALE 2:25

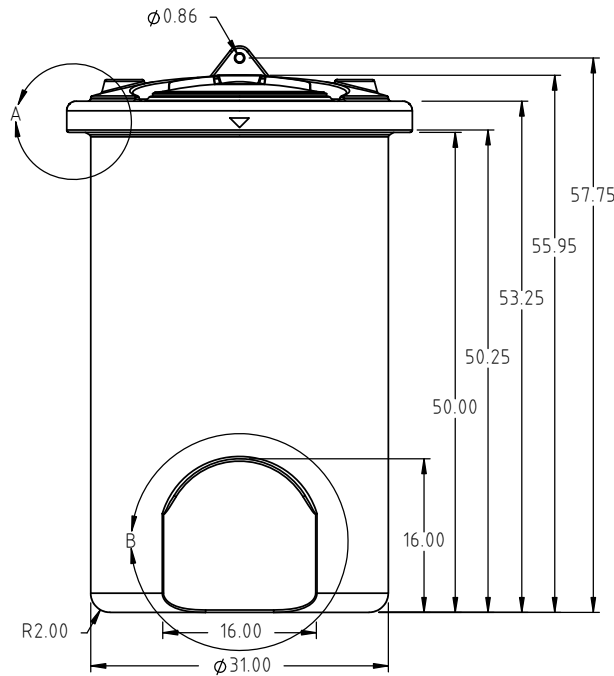

FITTING OPTIONAL

REV	DESCRIPTION	BY / DATE	CCN	DRAWN / DATE ADH 2/19/14	MATERIAL 10420
				APPRD. / DATE REH 10/17/14	
	ALL DIMENSIONS ARE IN DECIMAL INCHES TOLERANCES UNLESS OTHERWISE SPECIFIED	THIRD ANGLE PROJECTION ANSI 14.5M	SHOT WEIGHT: 51 LBS	NOTES: 1.) 0.210 NOM. WALL THICKNESS 2.) PATENT PENDING	
	POLYETHYLENE ±1% @ 68°F		SHIPPING WEIGHT:	DESCRIPTION 150 GALLON DUAL LINE™ TANK-INNER TANK	
	METAL DECIMAL ± .125" FRACTION ± 1/4" ANGLE ± 1°		FINISH:	SCALE N.S.	PART NO. DW0150-36-1



Den Hartog
INDUSTRIES, INC.

Ace Roto-Mold Injection Molding Blow Molding Sowjoy

4010 HOSPERS DRIVE S. BOX 425, HOSPERS, IOWA 51238-0425

Copyright. All information furnished within this document, electronic file or design correspondence is the property of Den Hartog Industries, Inc. and shall not be used, disclosed to others or copied without the expressed written consent of Den Hartog Industries, Inc.

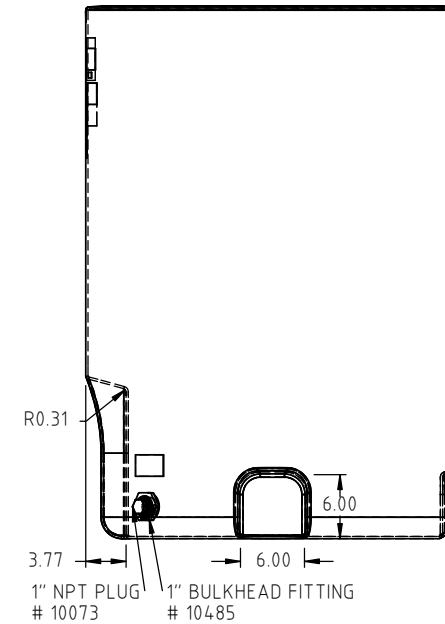
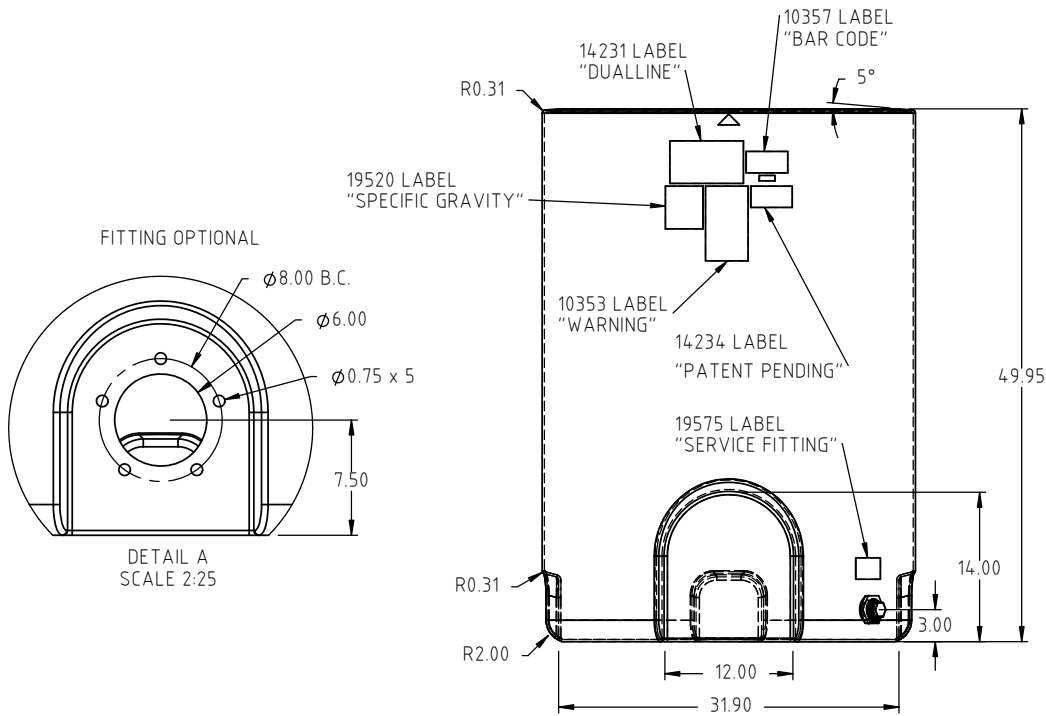
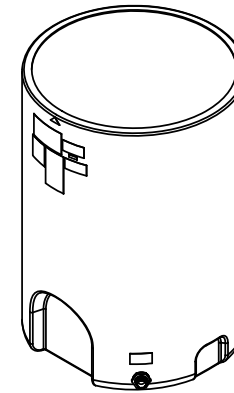
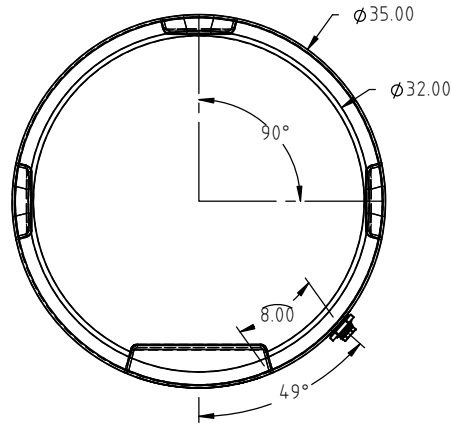

				DRAWN / DATE ADH 2/19/14	MATERIAL 10420
				APPRD. / DATE REH 10/17/14	
REV	DESCRIPTION	BY / DATE	CCN	SHOT WEIGHT: 52 LBS	NOTES: 1.) 0.210 NOM. WALL THICKNESS 2.) PATENT PENDING
				SHIPPING WEIGHT: 46 LBS.	
ALL DIMENSIONS ARE IN DECIMAL INCHES TOLERANCES UNLESS OTHERWISE SPECIFIED POLYETHYLENE ±1% @ 68°F		THIRD ANGLE PROJECTION ANSI 14.5M 		FINISH:	



Den Hartog

INDUSTRIES, INC.

Ace Roto-Mold Injection Molding Blow Molding Sowjoy

4010 HOSPERS DRIVE S. BOX 425, HOSPERS, IOWA 51238-0425

DESCRIPTION 150 GALLON DUAL LINE™ TANK- OUTER TANK	
SCALE N.S.	PART NO. DW0150-36-2