

SPHERE TANK INSTALLATION PROCEDURES [99800015]

Prior to the start of installation, record your model number and it's serial number. Model# _____ Serial # _____. This information will be required for any warranty claims. The installer must refer to, and comply with your state/county/local regulations. Snyder Installation instructions are secondary to these and should be used in conjunction with the state regulations.



1. Refer to SITE SELECTION/PREPARATION & DO's & DON'TS located at www.snydernet.com.

- Water runoff caused by sloping terrain, adjacent structures, or paved surfaces can be problematic if the site selection and installation are not managed properly. Refer to Snyder's SITE SELECTION/PREPARATION & DO'S & DON'TS located at www.snydernet.com on the proper methods of managing these issues. **Failure to locate the tank site properly in areas of water runoff caused by sloping terrain, adjacent structures or paved surfaces, and/or not managing the installation properly will void the warranty.**

2. Excavation [Figure 1]

- **Installer must comply with all state, county and local codes and use extreme safety when installing this tank.**
- Burial depth [A] (top of tank to finish grade) may range from 9" to 36".
- Side wall and end wall allowance [B] should be between 18" and 24".
- Bedding [C] must be a well-compacted 50% sand/gravel mixture with a minimum depth of 6" in soil terrain and 12" in rock terrain. Shift tank from side to side to help "settle" tank into bedding. USE 3/8" to 1/2" pea or river gravel. **DO NOT USE CRUSHED ROCK!**



- Do not over excavate or "belly-out" the excavation—KEEP BOTTOM OF EXCAVATION FLAT (as shown).
- Tank must be installed level side to side and end to end.
- In pumping applications, venting is critical. Insure venting back to the house is maintained or install a vent.

NOTE: FAILURE TO COMPLY WITH ABOVE WILL VOID TANK WARRANTY.

3. Lid and Manhole Extension [Figure 2]

- Install manhole extension (Riser) in accordance with state/county and local code requirements.
- Install the lid and/or manhole extension before the addition of backfill. (See back of this page for detail of lid and manhole extension installation.)
- Note that inlet is higher than the outlet.



NOTE: FAILURE TO COMPLY WITH ABOVE WILL VOID TANK WARRANTY.

4. Backfilling Exterior [Figure 3 & 4]

- Clean debris-free native soil can be used as backfill material, provided it does not create voids greater than 1/4".

NOTE: USE OF ANY SOIL CONTAINING CLAY FOR BACKFILL WILL VOID WARRANTY.

- **Backfill around the perimeter of the tank in 12" layers. Lightly compact each layer.** NEVER BACKFILL ON ONE SIDE ONLY. BACKFILL ALL OF THE OUTLINE OF THE SEPTIC TANK UNIFORMLY IN 12" LAYERS. [Figure 3].
- Backfill to the finish grade to a maximum depth of 36".
- **IMPORTANT:** Mound the soil over the septic tank to provide settling in the excavated area. The lid with riser must extend a maximum of 3" above finish grade or per applicable code. [Figure 4].



NOTE: FAILURE TO COMPLY WITH ABOVE WILL VOID TANK WARRANTY.

FAILURE TO FOLLOW ANY OF THESE INSTRUCTIONS WILL VOID THE WARRANTY.

IN NO CASE WILL SNYDER INDUSTRIES, INC. BE HELD LIABLE FOR ANY CONSEQUENTIAL DAMAGES.

www.snydernet.com

Phone: 402-467-5221 • Fax: 402-465-1229 • P.O. Box 4583 • Lincoln, NE 68504

June 2009 – Rev. 4

Figure 1

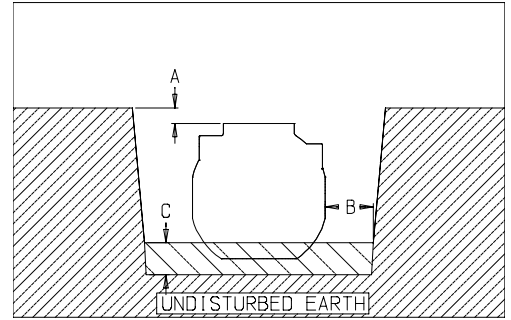

Figure 2

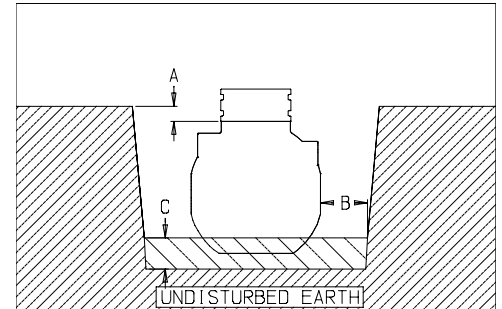

Figure 3

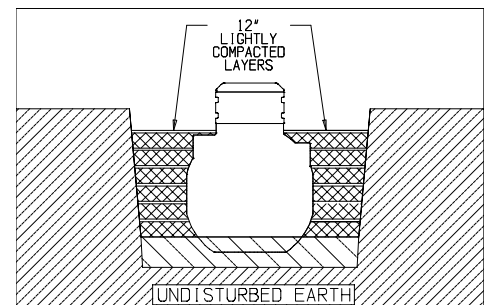
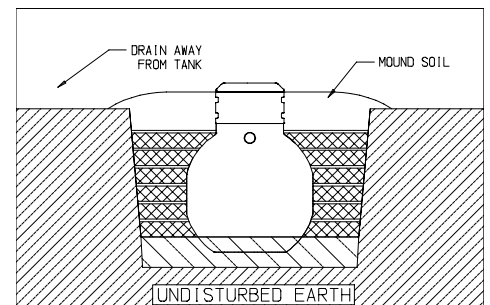

Figure 4



Sphere Tank Installation Procedures [99800015]

Figure 5

5. General

- Annual water table range must be determined prior to installation. Where saturated soil or seasonal high water tables are indicated above the bottom of the tank, immediately contact factory (402) 467-5221 or sales representative for special instructions.
- Do not install the tank in paths of heavy equipment or vehicular traffic.
- Tank is designed for underground use only.
- Never use sharp objects around the tank (including forklift tines). They may puncture the tank.
- Water temperature entering the tank must not exceed 130° F. Continuous operating temperatures above 100° F. are not recommended.
- Do not leave tank completely empty for extended periods of time.
- In pumping applications, venting is critical. Insure venting back to the house is maintained or install a vent. [Figure 5&6].
- Check local codes for height of vent above finish grade.
- For installation of additional tank accessories, it is important to check with local and state sanitarian for approved installation procedures.

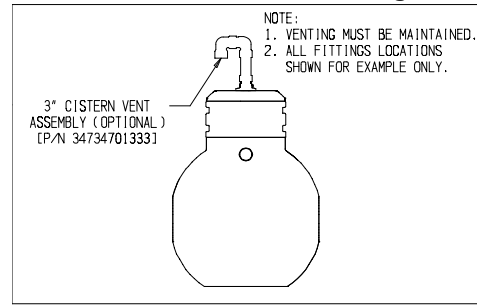

Figure 6

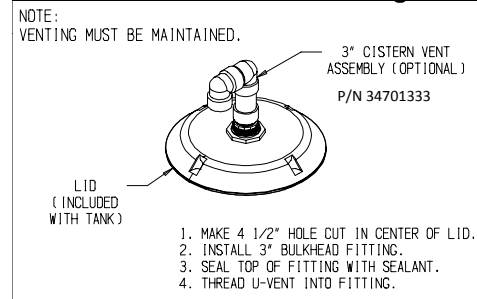

Figure 7

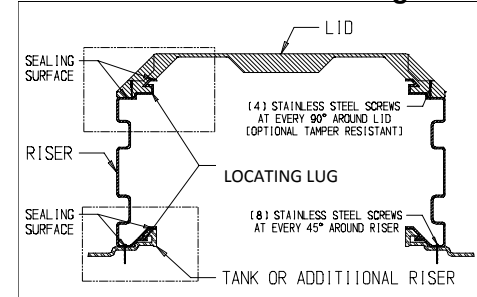

Figure 7.a.

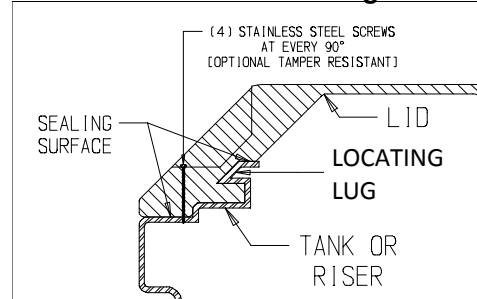
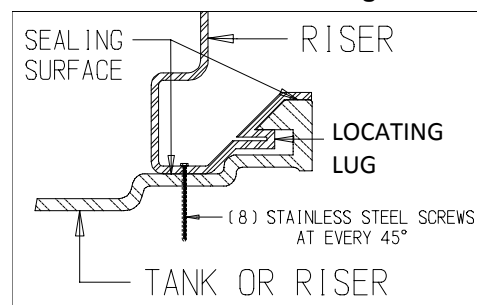

Figure 7.b.



NOTE: FAILURE TO COMPLY WITH ABOVE WILL VOID TANK WARRANTY

Securing Lid to Tank or Manhole Riser

[Figure 7 & 7.a.]

1. Apply appropriate sealant [butyl sealant meeting ASTM C 990 or a closed cell foam elastomeric gasket complying with ASTM D 1056, Type 2 Class C, Grade 1] to sealing surface(s). [Figure 7.a.]
2. Place lid onto the top of the tank and/or riser and line up the locating tabs. Install four self-tapping bolts (included) through the bolt holes in the lid and into the tank wall. [Figure 7.a.]

If tamper resistant bolts are required or desired, utilize bolts and driver bit supplied in tamper-resistant kit (part no. 34701197) optional.

NOTE: FAILURE TO COMPLY WITH ABOVE WILL VOID TANK WARRANTY

Securing Riser to Tank or to another Riser

[Figure 7 & 7.b.]

(Risers are stackable. Maintain the maximum 36" burial depth).

1. Apply appropriate sealant [butyl sealant meeting ASTM C 990 or a closed cell foam elastomeric gasket complying with ASTM D 1056, Type 2 Class C, Grade 1] to sealing surface(s) [Figure 7.b.]
2. Place riser onto the top of the tank and/or riser and line up the locating tabs. Install eight stainless steel screws (not supplied) at 45° intervals as shown in [Figure 7.b.].
3. Maintaining a watertight connection at each of these locations is critical to the operation of this septic tank.

NOTE: FAILURE TO COMPLY WITH ABOVE WILL VOID TANK WARRANTY

Warranty

Snyder warrants that if any manufactured tank product is proven to be defective in material or workmanship within three years from the date of manufacture, Snyder will (at company option) either replace or repair said part. This standard limited warranty does not apply to damages resulting from misuse, improper application of recommended materials, accident, or improper installation or maintenance. Remedy to the buyer is limited to the replacement of any defective product (or its component where applicable), F.O.B. point of manufacture. The buyer's remedy under this warranty does not include any other direct or indirect consequential damages which result from defects in material and/or workmanship of its products.

