



TQ Series 60Hz Electronic Control Pump

ISO 9001



Applications

The TQ series pumps are designed for water supply and pressure boosting in residential, commercial and light industrial applications where low or inadequate water pressure exists. It is suitable for boosting pressure from underground or surface water supplies.

Suitable liquids

Potable water or other clean or non-corrosive liquids.

Operation Conditions:

1. Ambient temperature: Max. +104°F (40°C)
2. Liquid temperature: +39°F(4°C) ~ +104°F (40°C)
3. System Pressure : Max. 85 PSI
4. Relative humidity: Max. 85% (RH)
5. Under normal operation, it is not necessary to adjust the pressure unless the cut in pressure is higher than preset activation point (refer to specification).

Product code



Product Features

1. The TQ is a complete, all-in-one unit, consisting of pump, motor, pressure tank, and electronic controller. The built-in electronic controller provides constant pressure which ensures that the pump starts automatically when water is consumed and operates continuously until water is not required.
2. Compact design and quiet operation make the TQ series suitable for many applications.
3. The TQ is constructed from the top quality corrosion resistant materials.
4. Pump has built in dry-run shut off with automatic reset function.
5. The motor has built-in thermal overload to protect against high operating temperatures and over current. (Single phase motor only)
6. The TQ has an anti-cycling feature which prevents the pump from continuous starting and stopping when you have a dripping tap or minor leak in the system.
7. The pumps will lift water up to 25 ft. with foot valve and pump suction piping filled with water.

Hydraulic Performance curve:

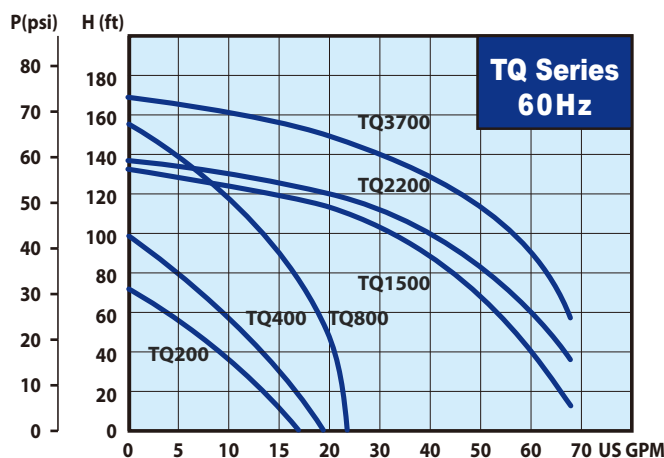

Materials

Part name	TQ200/400	TQ800	TQ1500/2200/3700
Pump casing	Glass filled noryl		
Filling plug	NyLon		
Outlet & Inlet	SUS 304		
Intermediate Chamber	Glass filled polycarbonate	SUS 304	
Impeller	Glass filled noryl	SUS 304	
Mechanical Seal	Ceramic+Carbon+NBR	Carbon+SiC+Viton	
Shaft	SUS 316		
Motor Shell	Coating Steel	Aluminum alloy	

Dimensions: (in.) TQ200/400/800

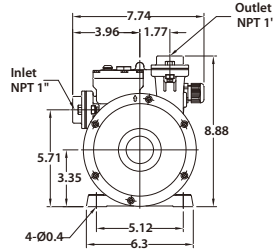
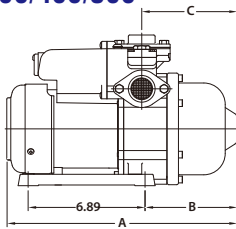

TQ1500/2200/3700

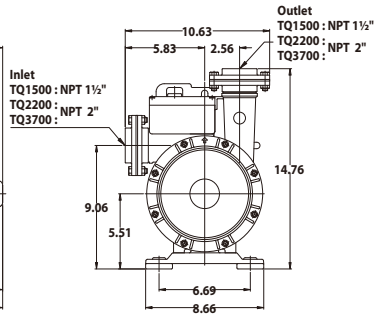
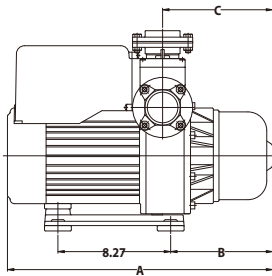

Model	A (in.)	B (in.)	C (in.)
TQ 200	13.23	5.08	5.28
TQ 400	13.56	5.43	5.63
TQ 800	16.42	6.46	6.65
TQ1500~3700	19.72	7.76	8.35

Specification:

Model	Power (HP)	Cycle (Hz)	Phase (Ø)	Voltage (V)	Amp's (A)	Inlet (NPT)	Outlet (NPT)	Preset activation pressure (psi)	Max discharge pressure (psi)	Q max. (GPM)	N.W. (lbs)
TQ200	¼	60	1	115 or 230	4.0 or 2.0	1"	1"	20	31	16.9	16.3
TQ400	½	60	1	115 or 230	6.0 or 3.0	1"	1"	28	40	18.5	19.6
TQ800	1	60	1	115 or 230	11.0 or 5.5	1"	1"	36	67	23.8	25.6
TQ1500	2	60	1 or 3	230	9.5 or 6.5	1½"	1½"	43	58	66.0	62.8
TQ2200	3	60	3	230	9.5	2"	2"	43	60	71.3	68.3
TQ3700	5	60	3	230	12	2"	2"	43	72	71.3	74.4

Suction Lift Performance Table

Model	Discharge pressure in psi	Capacity in US gallons per Minute					
		Suction Lift in Feet					
		0	5	10	15	20	25
TQ200	10	12.6	11.4	10.2	9.2	8.2	7.1
	20	7.7	6.4	5.2	3.8	2.4	0.5
TQ400	10	16.6	15.6	14.6	13.6	12.7	11.7
	20	12.0	11.0	10.0	9.0	7.8	6.6
	30	7.1	5.8	4.5	3.2	2.0	0.6
TQ800	10	22.4	22.1	21.7	21.3	20.8	20.5
	20	20.7	20.2	19.8	19.2	18.8	18.2
	30	18.3	17.8	17.1	16.2	15.3	14.2
	40	14.7	13.8	12.9	12.1	11.1	10.2
	50	10.5	9.3	8.1	6.9	5.6	4.3
TQ1500	10	66.2	65.0	63.7	62.0	60.2	58.1
	20	58.2	57.0	55.3	53.7	51.7	49.0
	30	50.0	47.3	44.3	41.8	39.7	37.2
	40	38.2	35.7	32.5	29.0	24.8	20.0
TQ2200	10	69.0	69.0	68.7	67.8	66.7	65.3
	20	65.8	64.4	62.8	61.2	59.3	57.2
	30	58.0	55.9	53.3	50.5	47.2	43.5
	40	45.0	41.2	37.6	34.1	30.0	24.6
TQ3700	10	70.9	70.4	70.0	69.5	69.2	68.7
	20	68.9	68.5	68.2	67.9	67.3	66.2
	30	66.7	65.5	64.2	62.8	61.3	59.8
	40	60.4	58.5	56.5	54.3	51.9	48.8
	50	50.0	46.6	42.8	39.0	35.8	32.6
60	34.0	30.4	25.8	20.0	12.7	5.7	

Note - The total system pressure will be :
"the inlet supply pressure + max pump boost pressure."